

FLOW-TEK

SERIES M4 SEVERE SERVICE METAL SEATED BALL VALVES

NPS ½ - 4 | DN 15-100 | ASME Limited and Standard Class 1700, 3100, 4500



 **Bray**[®]

WWW.BRAY.COM

THE HIGH PERFORMANCE COMPANY

M4 - SPECIFICATIONS

Size Range	NPS ½ - 2½ SW or BW DN 15 - 65	
	NPS 3 & 4 BW DN 80 & 100	
Bore Sizes	0.63"	
	1.03"	
	1.56"	
Body Materials¹	A105 A182-F22 Cl.3 A182-F91	
Ball Materials	410 SS/HVOF Chromium Carbide ² Inconel® 718/Fused Chromium Carbide	
Seat Materials	410 SS/HVOF Chromium Carbide ² Inconel® 718/HVOF Chromium Carbide	
Pressure Ratings	1700	½" thru 2½" Limited Class 3" and 4" Standard Class
	3100	
	4500	
Temperature	Up to 1100°F (593°C)	
End Connections³	SW per ASME B16.11	
	BW per ASME B16.25	
Design Standards	ASME B16.34 Bore sizes per ASME TDP-1	
Test Standards	Meets and exceeds API 598, or per customer request	
Characteristics	On/Off, Zero Leakage	

¹Other materials available on request.

²410 SS/HVOF not recommended for applications with ΔT above 700°F (371°C).

³Other end connections available on request.

FEATURES AND BENEFITS

- 1 Utilizing the same material and coating composition for the ball and seat, both parts expand at the same rate during thermal cycling, ensuring reliable tight shutoff.
 - > The ball and seat are 360° mate-lapped to create a truly spherical interface, eliminating irregularities found with traditional mate-lapping techniques.
 - > Wider sealing surfaces reduce dynamic cycling stresses promoting extended valve life and tight shutoff.
- 2 Forged heavy walled unibody construction eliminates the body joint and any potential for shell leakage.
 - > CNC machined for utmost accuracy.
 - > Transitioning angles maximize flow rates.
- 3 Cast steel bracket with increased thickness for superior rigidity.
 - > CNC machined to fully align the body, bracket, and stem, eliminating side to side motion.
 - > Permanently attached bracket.
- 4 High strength one piece stem with upper bearing ring.
 - > Ensures proper alignment.
 - > Extends valve life and maximizes stem sealing by limiting stem side loading.
 - > Prevents stem blow-out.
- 5 Robust ISO 5211 mounting flange supports direct mounting of high temperature actuators or conventional adaptation for standard actuators.
- 6 Inconel® 718 Belleville spring exerts continuous force onto the ball and seat maintaining the seal throughout operating temperatures.
- 7 Set of Inconel® 718 Belleville springs live load the stem packing for low maintenance leak prevention.
- 8 External body groove effectively dissipates conductive heat during the postweld heat treatment (PWHT) process.

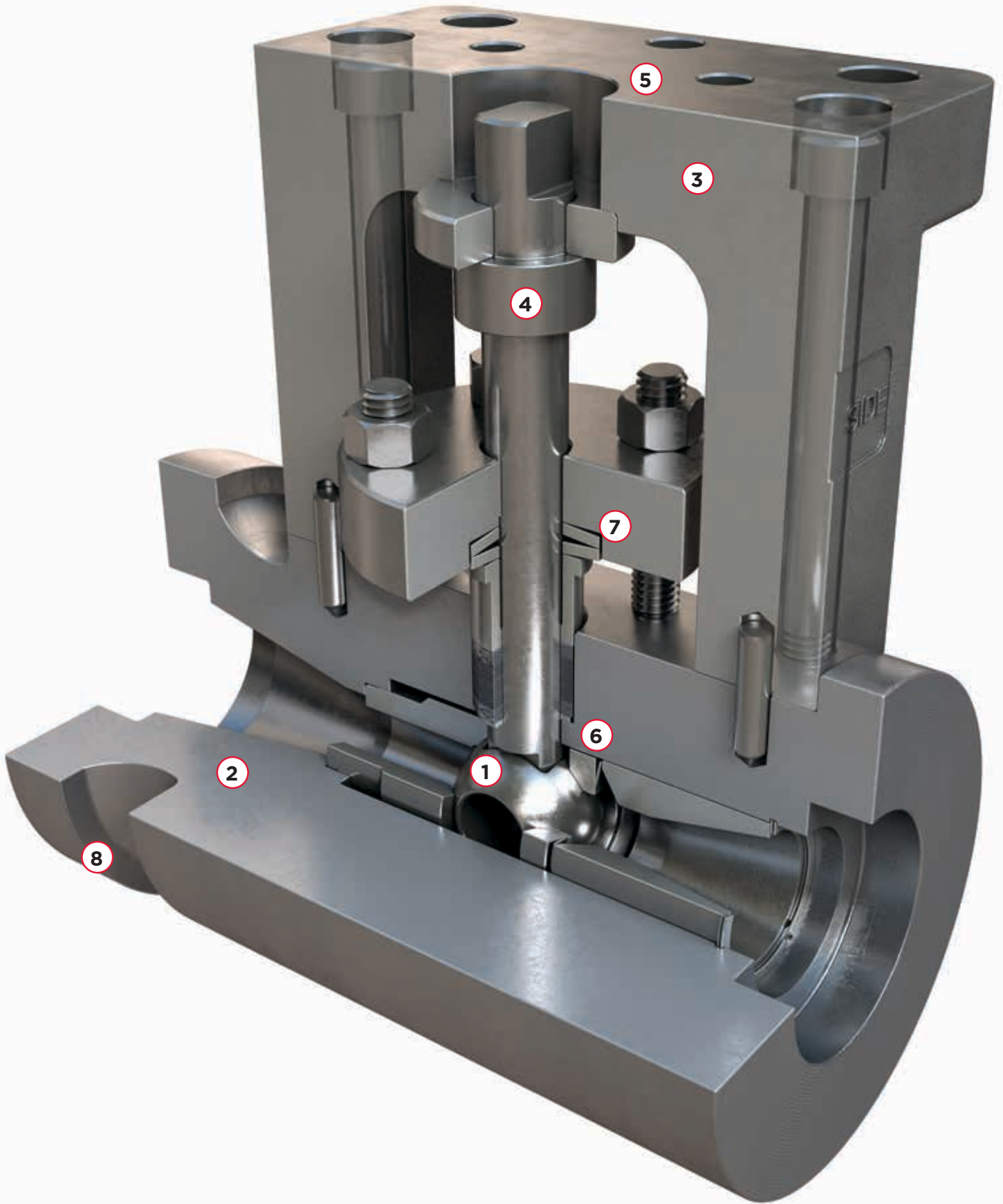

Specifically engineered for the most demanding high pressure and temperature steam applications, Flow-Tek's Series M4 is the culmination of advanced technology, rigorous testing, and decades of industry experience. Designed with long term performance and zero leakage in mind, the Series M4 is equipped with a robust drivetrain, a 360° mated-lapped ball and seat set, and the most advanced materials.

Coupled with Bray's exclusive range of actuation, solenoids, and limit switches, the Series M4 is available fully automated direct from any of our global locations. This maximizes value and quality for our customers.

Flow-Tek is dedicated to continuous improvement and innovation within our engineering, supply chain, and customer service processes. Our global presence allows us to provide the quality Bray products our customers have come to expect, worldwide.

QUALITY, SAFETY AND CERTIFICATION

- > **Standard 4 year performance warranty.***
- > As a result of our continual commitment to quality, our facilities have achieved ISO 9001:2008 for the design and manufacture of severe service valves.
- > We recognize that the safety of our product is critical to our customers, therefore, all pressure containing components are fully traceable.
- > Our severe service products are certified to the requirements of Annex III, Module H of PED 2014/68/EU, TSG, and CRN.

*Refer to Terms and Conditions for full details.

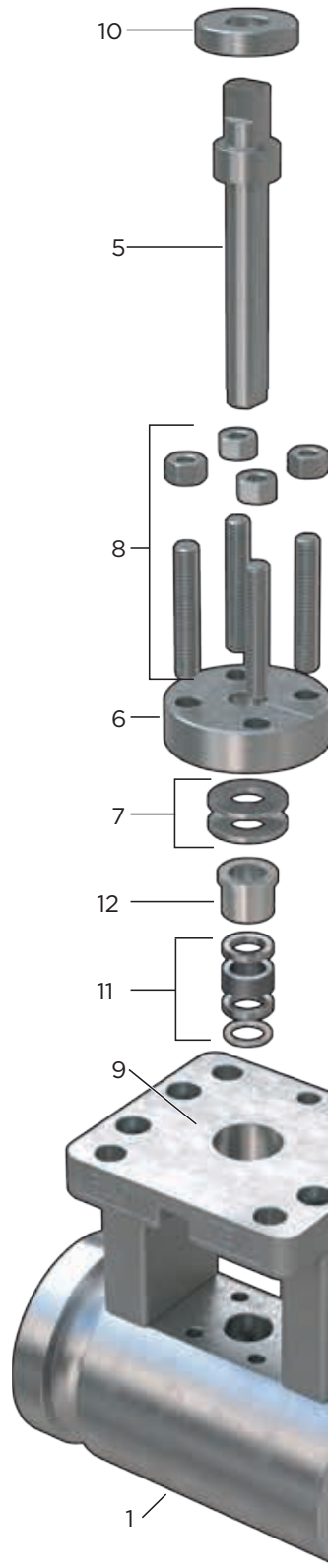

COMPONENTS & MATERIALS

ITEM	MATERIAL	QTY.	
1.	Body	A105, A182-F22 Cl. 3, A182-F91	1
2.	Ball	410 Stainless Steel/HVOF Chromium Carbide Inconel® 718/Fused Chromium Carbide	1
3.	Seat	410 Stainless Steel/HVOF Chromium Carbide Inconel® 718/HVOF Chromium Carbide	1
4.	Spring	Inconel® 718	1
5.	Stem	431 Stainless Steel/QPQ*	1
6.	Gland/Flange	316 Stainless Steel	1
7.	Live Loaded Spring	Inconel® 718	2
8.	Gland/Bolting	A193 B8M/8M	4
9.	Bracket	A217 WCB	1
10.	Upper Bearing Ring	416 Stainless Steel/Coated	1
11.	Packing	Graphite Ring Set with 316 Stainless Steel Anti-extrusion Ring	1
12.	Gland Follower	416 Stainless Steel/QPQ	1
13.	Pusher Seat	416 Stainless Steel/QPQ	1
14.	Transition Sleeve	416 Stainless Steel	1
15.	Retaining Ring	A638 Gr 660	1

*For 4500 Class & A182-F91 valves, stem material is Inconel® 718. Inconel® is a registered trademark of Special Metals Corporation.

High Pressure Side

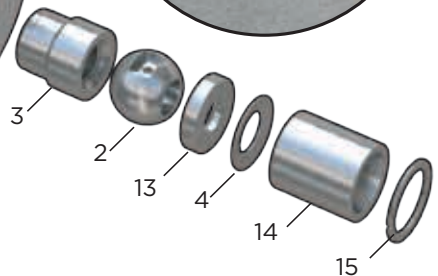
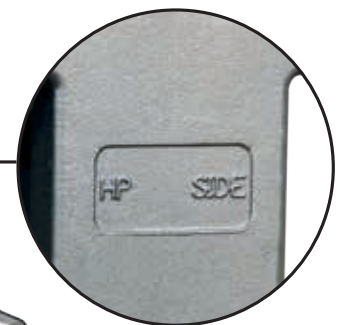

BALL VALVE

VS

GLOBE VALVE

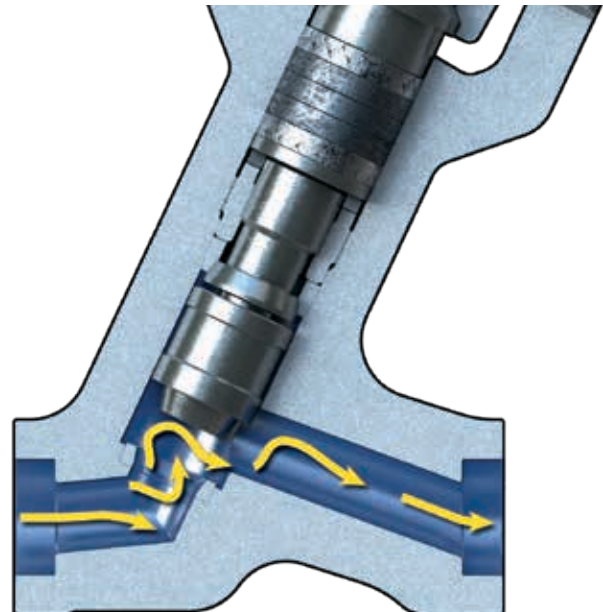
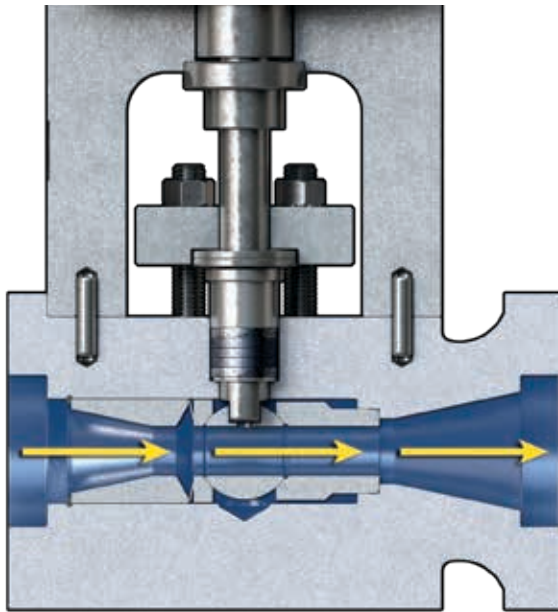
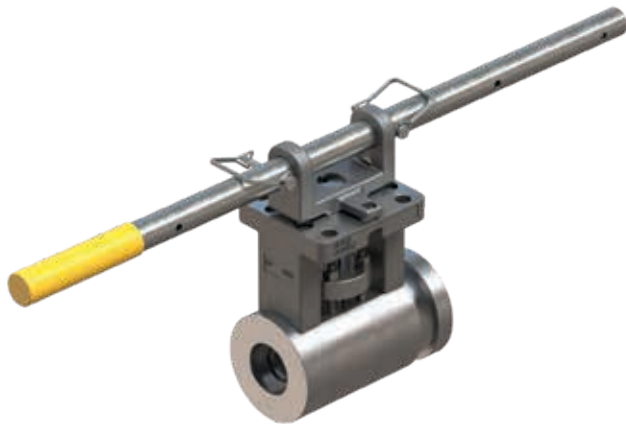

Spring and pressure assisted zero leakage shutoff occurs on a perfectly mate-lapped surface, ensuring repeatability over thousands of cycles.

Straight flow path increases the Cv while protecting the sealing surfaces from the flow, extending the valve's life.

Quarter turn stem rotation provides smooth operation and minimizes packing wear.

Quarter turn actuation is simple, compact, and easy to setup and maintain.

Valve closure relies solely on thrust or torque to press the disc into the seat, contributing to the continuous degradation of the sealing surfaces.

Turbulent flow path and constant exposure of sealing surfaces severely shortens the valve's life.

Stem travels through the entire packing in both directions, causing increased packing wear and the potential for leakage.

Linear actuators are typically larger, and often utilize complex exposed linkages requiring specialized calibration.

CONFIGURATIONS

SOCKET WELD

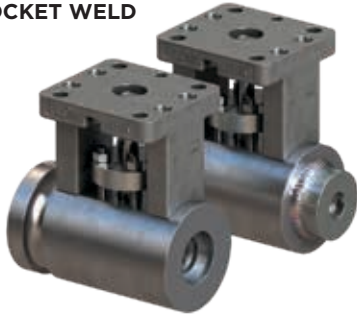

BUTT WELD



APPLICATIONS

Series M4 valves are ideally suited for high pressure/temperature steam lines in power plants and are commonly specified for use in Turbine Water Induction Prevention (TWIP) applications. These valves are an excellent fit for the following locations:

- > Inlet/Outlet Drains
- > Main Steam Stop Valve Before/After Seat Drains
- > Economizer Drains
- > Evaporator Drains
- > Superheater Drains
- > Condenser Drains
- > Turbine Drains
- > Crossover Drains
- > Startup Drains
- > Low Point Boiler Drains
- > High Point Boiler Vents
- > Boiler Blowdown Isolation

FLOW COEFFICIENTS

Pipe			Bore (inches) - Cv			Bore (mm) - Kv		
NPS	DN	Schedule No.	Cv is the volume (in US gallons) of water at 60°F that will flow per minute through a valve with a pressure drop of one psi across the valve			Kv is the rate of flow of cold water in cubic meters per hour at a pressure drop of one kilogram per square centimeter across the valve		
			0.63	1.03	1.56	16	26	40
½	15	STD/40	20	-	-	17.2	-	-
		XS/80	14	-	-	12.1	-	-
		160	-	-	-	-	-	-
		XXS	-	-	-	-	-	-
¾	20	STD/40	20	-	-	17.2	-	-
		XS/80	22	-	-	19.0	-	-
		160	19	-	-	16.4	-	-
		XXS	8	-	-	6.9	-	-
1	25	STD/40	17	71	-	14.7	61.2	-
		XS/80	18	63	-	15.5	54.3	-
		160	21	39	-	18.1	33.6	-
		XXS	18	18	-	15.5	15.5	-
1-½	40	STD/40	14	48	191	12.1	41.4	164.6
		XS/80	14	51	188	12.1	44.0	162.1
		160	15	58	143	12.9	50.0	123.3
		XXS	16	71	71	13.8	61.2	61.2
2	50	STD/40	-	41	135	-	35.3	116.4
		XS/80	-	42	148	-	36.2	127.6
		160	14	46	183	12.1	39.7	157.7
		XXS	14	51	189	12.1	44.0	162.9
2-½	65	STD/40	-	-	111	-	-	95.7
		XS/80	-	-	117	-	-	100.9
		160	-	-	130	-	-	112.1
		XXS	-	-	170	-	-	146.5
3	80	STD/40	-	-	96	-	-	82.8
		XS/80	-	-	99	-	-	85.3
		160	-	-	105	-	-	90.5
		XXS	-	-	119	-	-	102.6
4	100	STD/40	-	-	86	-	-	74.4
		XS/80	-	-	87	-	-	75.3
		160	-	-	91	-	-	78.5
		XXS	-	-	94	-	-	81.3

PRESSURE/TEMPERATURE RATINGS - IMPERIAL

NPS ½ - 2½ PER ASME B16.34 LIMITED Class (2013 edition)

Material	A105						A182 F22 Cl.3						A182 F91					
	Class	900	1500	1700	2500	3100	4500	900	1500	1700	2500	3100	4500	900	1500	1700	2500	3100
Degrees °F	psig						psig						psig					
-20° to 100°	2,250	3,750	4,250	6,250	7,750	11,250	2,250	3,750	4,250	6,250	7,750	11,250	2,250	3,750	4,250	6,250	7,750	11,250
200°	2,250	3,750	4,250	6,250	7,750	11,250	2,250	3,750	4,250	6,250	7,750	11,250	2,250	3,750	4,250	6,250	7,750	11,250
300°	2,250	3,700	4,194	6,170	7,651	11,105	2,220	3,695	4,188	6,160	7,639	11,090	2,250	3,750	4,250	6,250	7,750	11,250
400°	2,200	3,665	4,153	6,105	7,572	10,995	2,185	3,640	4,125	6,065	7,520	10,915	2,250	3,750	4,250	6,250	7,750	11,250
500°	2,200	3,665	4,153	6,105	7,572	10,995	2,175	3,620	4,103	6,035	7,484	10,865	2,250	3,750	4,250	6,250	7,750	11,250
600°	2,200	3,665	4,153	6,105	7,572	10,995	2,165	3,605	4,086	6,010	7,452	10,815	2,250	3,750	4,250	6,250	7,750	11,250
650°	2,145	3,575	4,052	5,960	7,391	10,730	2,145	3,580	4,057	5,965	7,396	10,735	2,250	3,750	4,250	6,250	7,750	11,250
700°	2,075	3,455	3,916	5,760	7,142	10,365	2,120	3,535	4,007	5,895	7,308	10,605	2,200	3,665	4,154	6,110	7,576	10,995
750°	1,905	3,170	3,593	5,285	6,554	9,515	2,120	3,535	4,007	5,895	7,308	10,605	2,185	3,645	4,130	6,070	7,528	10,930
800°	1,545	2,570	2,913	4,285	5,314	7,715	2,120	3,535	4,007	5,895	7,308	10,605	2,160	3,600	4,080	6,000	7,440	10,800
850°	Permissible but not recommended for prolonged use above 800°F						2,030	3,385	3,837	5,645	7,000	10,160	2,030	3,385	3,837	5,645	7,000	10,160
900°							1,800	3,000	3,400	5,000	6,200	9,000	1,800	3,000	3,400	5,000	6,200	9,000
950°							1,415	2,360	2,624	3,930	4,872	7,070	1,415	2,360	2,674	3,930	4,872	7,070
1000°							1,045	1,785	2,042	3,119	3,983	6,213	1,260	2,105	2,385	3,505	4,347	6,310
1050°							681	1,170	1,337	2,038	2,604	4,064	1,260	2,105	2,385	3,505	4,347	6,310
1100°							426	732	838	1,282	1,635	2,546	1,175	2,015	2,284	3,360	4,166	6,045

PRESSURE/TEMPERATURE RATINGS - METRIC

DN 15-65 PER ASME B16.34 LIMITED Class (2013 edition)

Material	A105						A182 F22 Cl.3						A182 F91					
	Class	900	1500	1700	2500	3100	4500	900	1500	1700	2500	3100	4500	900	1500	1700	2500	3100
Degrees °C	barg						barg						barg					
-29° to 38°	155.1	258.6	293.1	430.9	534.3	775.7	155.1	258.6	293.1	430.9	534.3	775.7	155.1	258.6	293.1	430.9	534.3	775.7
50°	155.1	258.6	293.1	430.9	534.3	775.7	155.1	258.6	293.1	430.9	534.3	775.7	155.1	258.6	293.1	430.9	534.3	775.7
100°	154.9	258.2	292.6	430.3	533.6	774.5	154.9	258.1	292.5	430.2	533.4	774.3	155.1	258.6	293.1	430.9	534.3	775.7
150°	153.1	255.2	289.2	425.3	527.4	765.5	152.9	254.8	288.8	424.6	526.5	764.3	155.1	258.6	293.1	430.9	534.3	775.7
200°	151.7	252.9	286.6	421.4	522.6	758.6	150.7	251.1	284.6	418.5	519.0	753.4	155.1	258.6	293.1	430.9	534.3	775.7
250°	151.6	252.6	286.3	421.1	522.1	757.9	149.9	249.9	283.2	416.5	516.5	749.7	155.1	258.6	293.1	430.9	534.3	775.7
300°	151.6	252.6	286.3	421.1	522.1	757.9	149.3	248.9	282.1	414.8	514.4	746.7	155.1	258.6	293.1	430.9	534.3	775.7
325°	150.3	250.6	284.0	417.6	517.8	751.7	148.8	248.0	281.1	413.3	512.5	743.9	155.1	258.6	293.1	430.9	534.3	775.7
350°	146.7	244.6	277.2	407.6	505.4	733.7	147.6	246.0	278.8	410.0	508.4	738.1	154.3	257.1	291.4	428.6	531.4	771.4
375°	141.3	235.5	266.9	392.5	486.7	706.5	146.3	243.8	276.3	406.3	503.8	731.3	151.5	252.5	286.2	420.9	521.9	757.4
400°	130.2	217.0	245.9	361.7	448.5	651.0	146.3	243.8	276.3	406.3	503.8	731.3	150.6	251.2	284.6	418.3	518.8	753.2
425°	107.9	179.8	203.8	299.6	371.5	539.3	146.3	243.8	276.3	406.3	503.8	731.3	148.9	248.2	281.3	413.7	513.0	744.6
450°	Permissible but not recommended for prolonged use above 425°C						141.4	235.8	267.3	393.1	487.5	707.6	141.4	235.8	267.3	393.1	487.5	707.6
475°							128.2	213.7	242.2	356.3	441.8	641.3	128.2	213.7	242.2	356.3	441.8	641.3
500°							107.1	178.6	202.4	297.5	368.9	535.4	107.1	178.6	202.4	297.5	368.9	535.4
538°							71.9	123.1	140.8	215.2	274.7	428.3	90.4	155.1	177.3	270.7	345.6	535.4
550°							61.0	104.4	119.4	182.3	232.8	363.1	86.9	145.1	164.4	241.7	299.7	435.1
575°							41.1	70.3	80.4	122.9	156.8	244.6	86.9	145.1	164.4	241.7	299.7	435.1
600°							26.8	46.0	52.6	80.3	102.5	159.9	76.0	130.3	149.0	227.5	290.4	428.8

SOCKET WELD

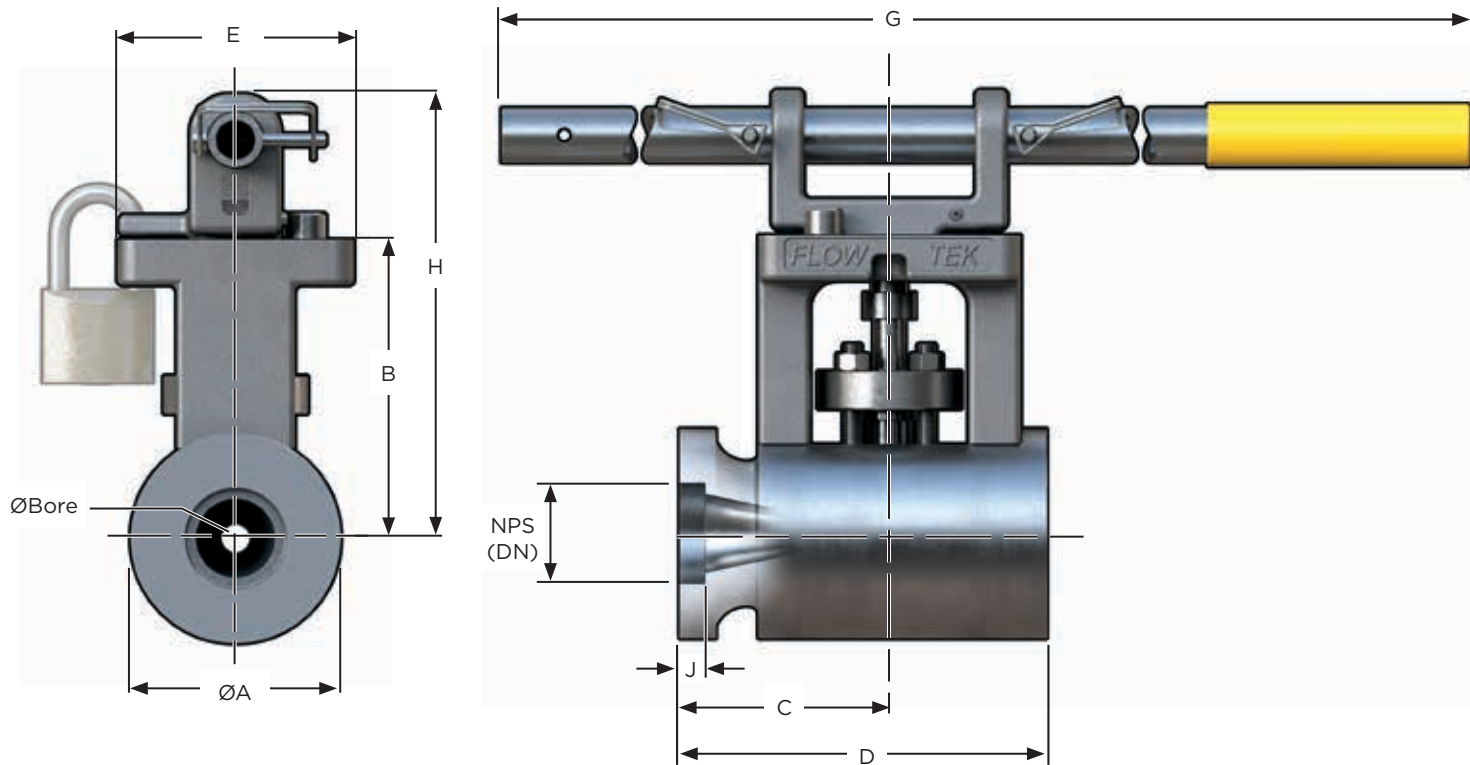

SOCKET WELD VALVE DIMENSIONS - IMPERIAL

Ø Bore in.	Pipe Size NPS	Up to ASME 3100	ASME 4500	B in.	Up to ASME 3100		ASME 4500		E in.	ØF ISO 5211	G in.	H in.	J Socket Depth in.	Weight Valve/Handle Assy. lbs.
		ØA in.	ØA in.		C in.	D in.	C in.	D in.						
0.63	½	4.00	4.00	5.69	4.00	7.98	4.00	7.98	4.50	F12	28.00	8.45	0.38	39
	¾	4.00	4.00		4.00	8.37	4.00	8.37					0.50	39
	1	4.00	4.00		4.00	7.00	4.00	7.00					0.50	38
	1½	4.00	4.00		4.00	7.00	4.25	7.63					0.50	39
	2	4.50	4.50		4.65	8.50	4.65	8.50					0.62	49
1.03	¾	4.75	4.75	6.45	5.54	10.34	5.54	10.34	5.50	F12/F16	36.00	9.51	0.50	65
	1	4.75	4.75		4.50	9.58	4.50	9.58					0.50	66
	1½	4.75	4.75		4.50	8.25	4.50	8.25					0.50	62
	2	4.75	5.50		4.50	8.25	5.13	9.75					0.62	81
	2½	5.50	5.50		5.13	9.75	5.25	9.88					0.62	81
1.56	1½	5.75	Not Applicable	8.33	5.25	10.42	Not Applicable	5.50	F16	Not Applicable	0.50	83		
	2	5.75			5.13	10.77							0.62	86
	2½	5.75			5.13	9.00							0.62	79

For other valve configurations, consult the factory. Information subject to change; for the latest updates, please visit our website flow-tek.com

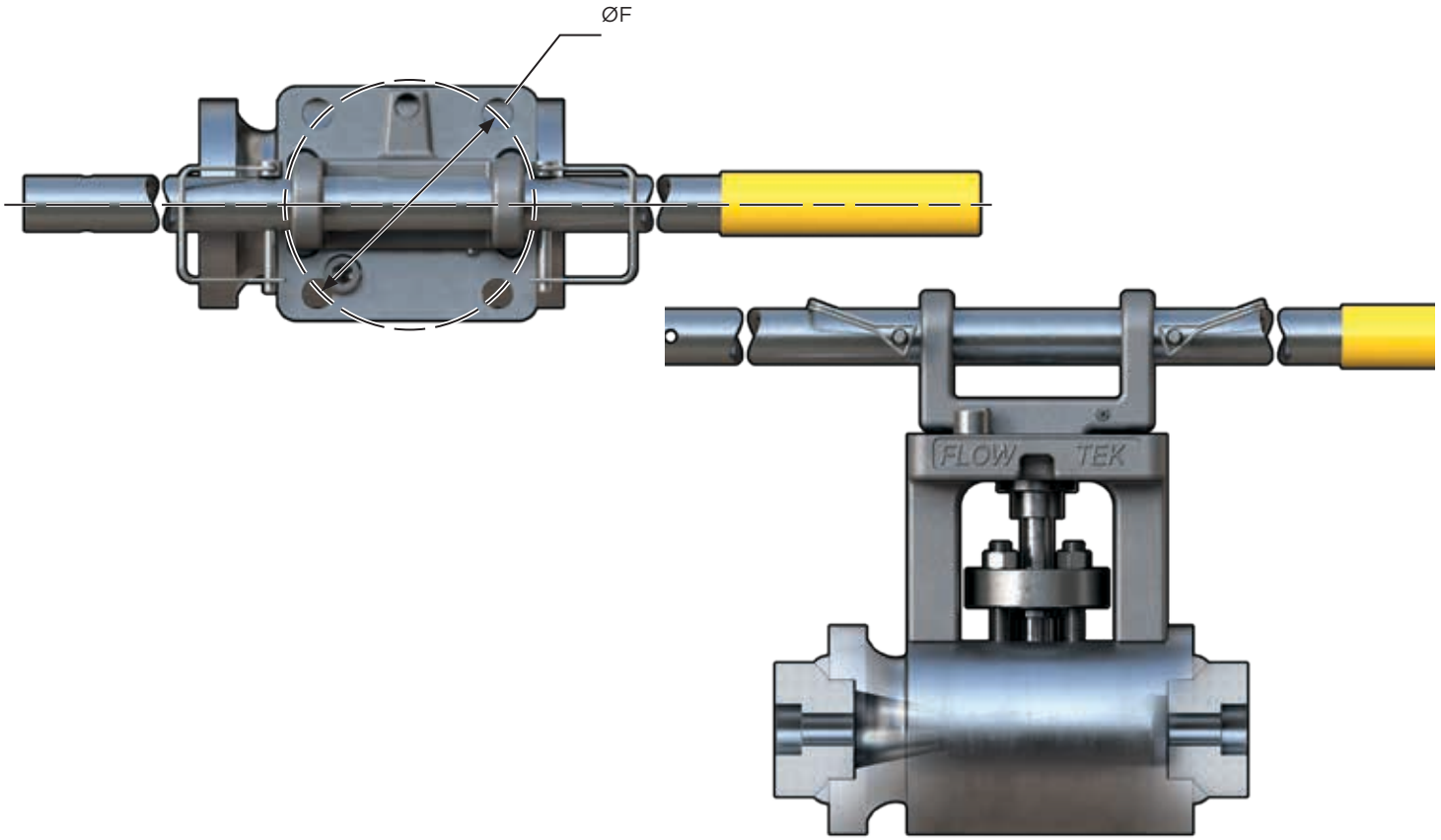

Shown with pup joint.

SOCKET WELD VALVE DIMENSIONS - METRIC

Ø Bore mm	Pipe Size DN	Up To ASME 3100	ASME 4500	B mm	Up to ASME 3100		ASME 4500		E mm	ØF ISO 5211	G mm	H mm	J Socket Depth mm	Weight Valve/Handle Assy. Kg
		ØA mm	ØA mm		C mm	D mm	C mm	D mm						
16	15	102	102	145	102	203	102	203	114	F12	711	215	10	18
	20	102	102		102	213	102	213					13	18
	25	102	102		102	178	102	178					13	17
	40	102	102		102	178	108	194					13	18
	50	114	114		118	216	118	216					16	22
26	20	121	121	164	141	263	141	263	140	F12/F16	914	242	13	29
	25	121	121		114	243	114	243					13	29
	40	121	121		114	210	114	210					13	28
	50	121	140		114	210	130	248					16	37
	65	140	140		130	248	133	251					16	37
40	40	146	Not Applicable	212	133	265	Not Applicable	140	F16	Not Applicable	16	16	13	38
	50	146			130	274							16	39
	65	146			130	229							16	36

For other valve configurations, consult the factory. Information subject to change; for the latest updates, please visit our website flow-tek.com

BUTT WELD

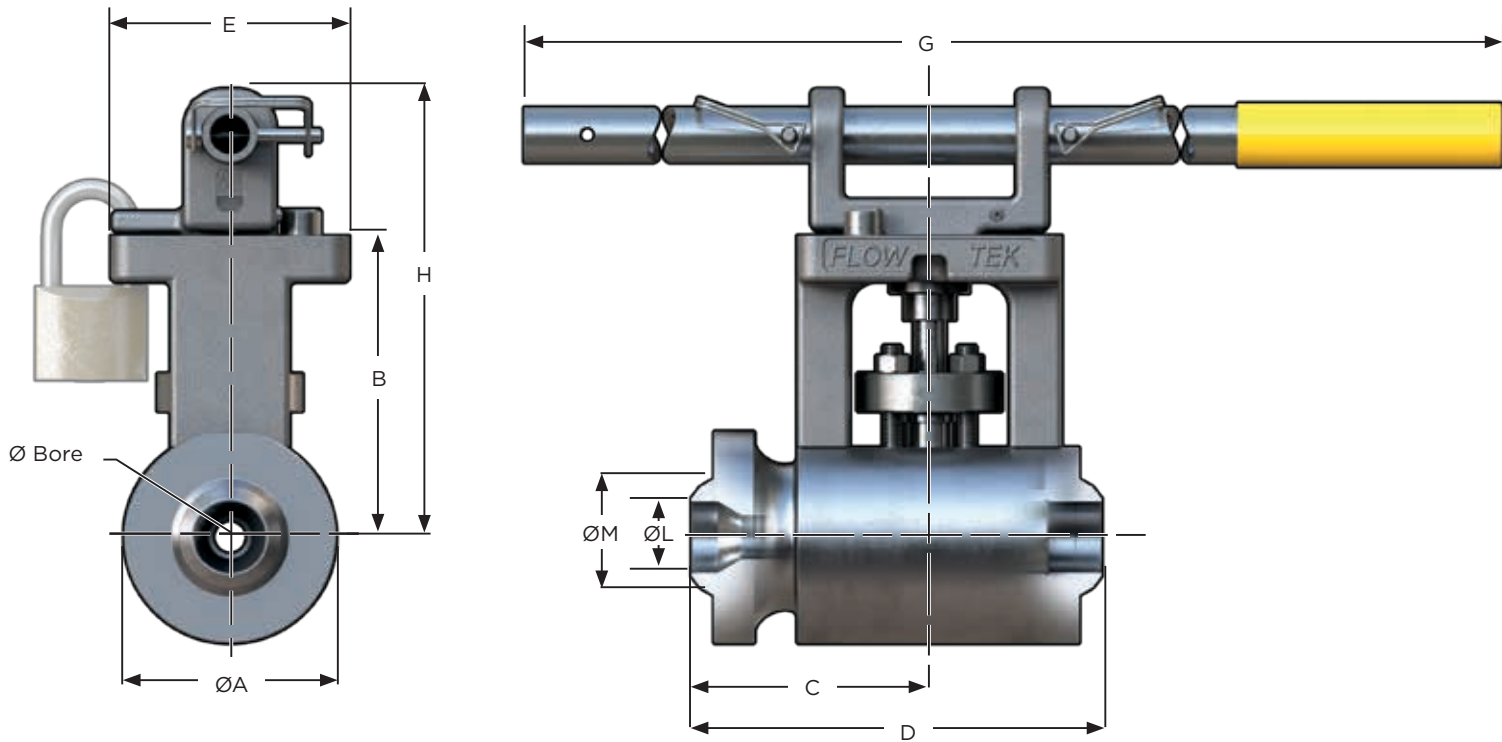

BUTT WELD VALVE DIMENSIONS - IMPERIAL

Ø Bore in	Pipe Size NPS	Pipe* Schedule	Class	ØA in.	B in.	C in.	D in.	E in.	ØF ISO 5211	G in.	H in.	K in.	ØL Pipe ID in.	ØM Pipe OD in.	Weight Valve/Handle Assy. lbs.										
0.63	1	160	Up to ASME 4500 LTD	4.00	5.69	4.50	9.88	4.50	F12	28.00	8.45	5.00	0.815	1.315	42										
		XXS					9.88						0.599	1.315	42										
	1½	160					7.75						1.338	1.900	42										
		XXS					9.88						1.100	1.900	42										
	2	160					7.75						1.687	2.375	41										
		XXS					7.75						1.503	2.375	41										
1.03	1½	160	Up to ASME 4500 LTD	4.75	6.45	5.25	12.33	5.50	F12/ F16	36.00	9.51	6.00	1.338	1.900	72										
		XXS					12.33						1.100	1.900	71										
	2	160					12.33						1.687	2.375	71										
		XXS					12.33						1.503	2.375	71										
	2½	160					9.20						2.125	2.875	67										
		XXS					12.33						1.771	2.875	70										
	3	160					9.20						2.624	3.500	66										
		XXS					9.20						2.300	3.500	66										
	1.56	2					160						Up to ASME 3100 LTD	5.75	8.33	5.73	13.73	5.50	F16	-	-	6.75	1.687	2.375	90
							XXS										13.73						1.503	2.375	90
2½		160	13.73	2.125	2.875	90																			
		XXS	13.73	1.771	2.875	90																			
3		160	13.73	2.624	3.500	89																			
		XXS	13.73	2.300	3.500	89																			
4		160	10.10	3.438	4.500	80																			
		XXS	10.10	3.152	4.500	80																			

*Other pipe schedules available upon request.

For other valve configurations, consult the factory. Information subject to change; for the latest updates, please visit our website flow-tek.com

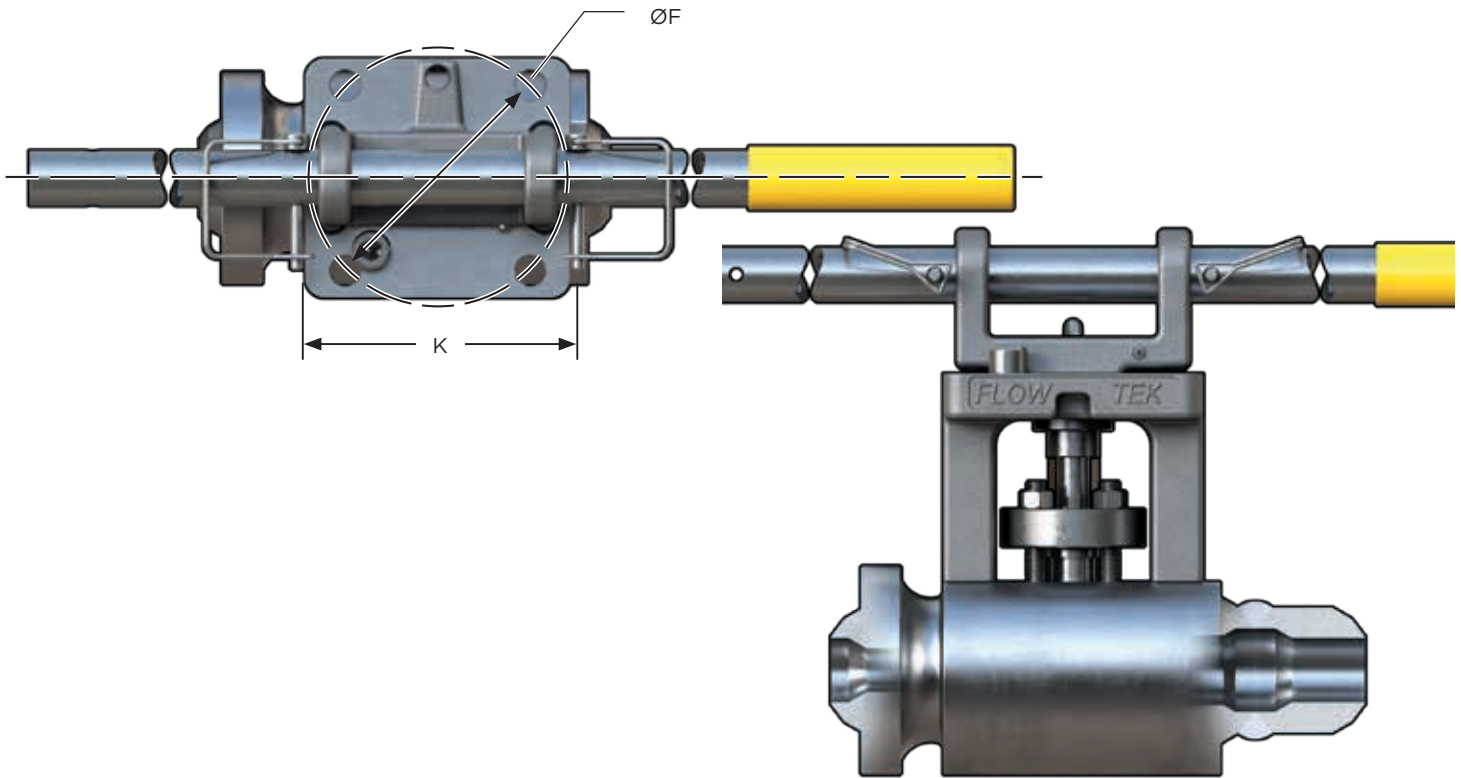

Shown with pup joint.

BUTT WELD VALVE DIMENSIONS - METRIC

Ø Bore mm	Pipe Size DN	Pipe* Schedule	Class	ØA mm	B mm	C mm	D mm	E mm	ØF ISO 5211	G mm	H mm	K mm	ØL Pipe ID mm	ØM Pipe OD mm	Weight Valve/Handle Assy. kg										
16	25	160	Up to ASME 4500 LTD	102	145	114	251	114	F12	711	215	127	21	33	19										
		XXS					251						15	33	19										
	40	160					197						34	48	19										
		XXS					251						28	48	19										
	50	160					197						43	60	19										
		XXS					197						38	60	19										
26	40	160	Up to ASME 4500 LTD	121	164	133	313	140	F12/ F16	914	242	152	34	48	33										
		XXS					313						28	48	32										
	50	160					313						43	60	32										
		XXS					313						38	60	32										
	65	160					234						54	73	30										
		XXS					313						45	73	32										
	80	160					234						67	89	30										
		XXS					234						58	89	30										
	40	50					160						Up to ASME 3100 LTD	146	212	146	349	140	F16	-	-	171	43	60	41
							XXS										349						38	60	41
65		160	349	54	73	41																			
		XXS	349	45	73	41																			
80		160	Up to ASME 3100	349	67	40																			
		XXS		349	58	89	40																		
100		160		257	87	114	36																		
		XXS		257	80	114	36																		

*Other pipe schedules available upon request.

For other valve configurations, consult the factory. Information subject to change; for the latest updates, please visit our website flow-tek.com

SINCE 1986, BRAY HAS PROVIDED FLOW CONTROL SOLUTIONS FOR A VARIETY OF INDUSTRIES AROUND THE WORLD.

VISIT BRAY.COM TO LEARN MORE ABOUT BRAY PRODUCTS AND LOCATIONS NEAR YOU.

HEADQUARTERS

BRAY INTERNATIONAL, INC.

13333 Westland East Blvd.
Houston, Texas 77041
Tel: 281.894.5454

All statements, technical information, and recommendations in this bulletin are for general use only. Consult Bray representatives or factory for the specific requirements and material selection for your intended application. The right to change or modify product design or product without prior notice is reserved. Patents issued and applied for worldwide.

© 2021 BRAY INTERNATIONAL, INC. ALL RIGHTS RESERVED.

F-2806_EL_M4_SEVERE SERVICE_2021-02



THE HIGH PERFORMANCE COMPANY

BRAY.COM